

INSTRUCTION MANUAL FOR WIRE WELDING MACHINE

IMPORTANT: BEFORE STARTING THE EQUIPMENT, READ THE CONTENTS OF THIS MANUAL, WHICH MUST BE STORED IN A PLACE FAMILIAR TO ALL USERS FOR THE ENTIRE OPERATIVE LIFE-SPAN OF THE MACHINE. THIS EQUIPMENT MUST BE USED SOLELY FOR WELDING OPERATIONS.

FOR THE DIMENSIONS AND WEIGHT OF THIS WELDING MACHINE, SEE THE SPECIFIC CATALOGUE.

1 SAFETY PRECAUTIONS

WELDING AND ARC CUTTING CAN BE HARMFUL TO YOURSELF AND OTHERS. The user must therefore be educated against the hazards, summarized below, deriving from welding operations. For more detailed information, order the manual code 3.300.758

ELECTRIC SHOCK - May be fatal.



- Install and earth the welding machine according to the applicable regulations.

- Do not touch live electrical parts or electrodes with bare skin, gloves or wet clothing.

- Isolate yourselves from both the earth and the workpiece.

- Make sure your working position is safe.

FUMES AND GASES - May be hazardous to your health.



- Keep your head away from fumes.

- Work in the presence of adequate ventilation, and use ventilators around the arc to prevent gases from forming in the work area.

ARC RAYS - May injure the eyes and burn the skin.



- Protect your eyes with welding masks fitted with filtered lenses, and protect your body with appropriate safety garments.

- Protect others by installing adequate shields or curtains.

RISK OF FIRE AND BURNS



- Sparks (sprays) may cause fires and burn the skin; you should therefore make sure there are no flammable materials in the area, and wear appropriate protective garments.

NOISE



This machine does not directly produce noise exceeding 80dB. The plasma cutting/welding procedure may produce noise levels beyond said limit; users must therefore implement all precautions required by law.

PACEMAKERS

- The magnetic fields created by high currents may affect the operation of pacemakers. Wearers of vital electronic equipment (pacemakers) should consult their physician before beginning any arc welding, cutting, gouging or spot welding operations.

EXPLOSIONS



- Do not weld in the vicinity of containers under pressure, or in the presence of explosive dust, gases or fumes.
- All cylinders and pressure regulators used in welding operations should be handled with care.

ELECTROMAGNETIC COMPATIBILITY

This machine is manufactured in compliance with the instructions contained in the harmonized standard EN50199, **and must be used solely for professional purposes in an industrial environment. There may be potential difficulties in ensuring electromagnetic compatibility in non-industrial environments.**

IN CASE OF MALFUNCTIONS, REQUEST ASSISTANCE FROM QUALIFIED PERSONNEL.

2 GENERAL DESCRIPTION

2.1 SPECIFICATIONS

This manual has been prepared for the purpose of educating personnel assigned to install, operate and service the welding machine.

This equipment is a constant-voltage power source, suitable for MIG/MAG and OPEN-ARC welding.

Upon receiving the machine, make sure there are no broken or damaged parts.

The purchaser should address any complaints for losses or damage to the vector. Please indicate the article and serial number whenever requesting information about the welding machine.

2.2 EXPLANATION OF TECHNICAL SPECIFICATIONS

EN 50199
EN60974.1

The welding machine is manufactured according to these international standards.

N°
indi-

serial number, which must always be indicated on any type of request regarding the welding machine.



Single-phase transformer - rectifier



three-phase transformer-rectifier.



Flat characteristic.

MIG/MAG.
I2 max

Suitable for continuous electrode welding. Unconventional welding current. This value represents the max. limit attainable in welding.

U0.

Secondary open-circuit voltage.

X.

Duty cycle percentage.

The duty cycle expresses the percentage of 10 minutes during which the welding machine may run at a certain current without overheating.

I2.

Welding current

U2.

Secondary voltage with welding current I2.

U1.

Rated supply voltage

1~ 50/60Hz

50- or 60-Hz single-phase power supply.

3~ 50/60Hz

50- or 60-Hz three-phase power supply.

I1 max

Maximum absorbed current value.

I1 eff

This is the maximum value of the actual current absorbed, considering the duty cycle.

IP21C

Protection rating for the housing.

Grade 1 as the second digit means that this equipment is suitable for use outdoors in the rain.

The additional letter C means that the

equipment is protected against access to the live parts of the power supply circuit by a tool (diameter 2.5 mm).

Suitable for use in high-risk environments.

S

NOTES: The welding machine has also been designed for use in environments with a pollution rating of 3. (See IEC 664).

2.3 Overload cut-out

This machine is protected by a thermostat, which prevents the machine from operating if the allowable temperatures are exceeded. In these conditions the fan continues to operate and the lamp F lights.

3 INSTALLATION

- Only skilled personnel should install the machine .
 - All connections must be carried out according to current regulations, and in full observance of safety laws. Make sure that the supply voltage corresponds to the value indicated on the power cable. If it is not already fitted, connect a plug suited to the power cable, making sure that the yellow/green conductor is connected to the earth pin.
- The capacity of the overload cutout switch or fuses installed in series with the power supply must be equivalent to the absorbed current I1 max. of the machine.

3.1 PLACEMENT

Mount the handle, rear wheels and the two cylinder supports.

The handle must not be used for lifting the welding machine.

Place the welding machine in a ventilated area.

Dust, dirt, and any other foreign matter entering the welding machine can interfere with ventilation and thus with smooth operation.

Therefore, in relation to the environment and working conditions, it is important to keep the internal parts clean. Clean using a jet of dry, clean air, being careful to avoid damaging the machine in any way.

Before working inside the welding machine, make sure it is unplugged from the power mains.

Any intervention carried out inside the welding machine

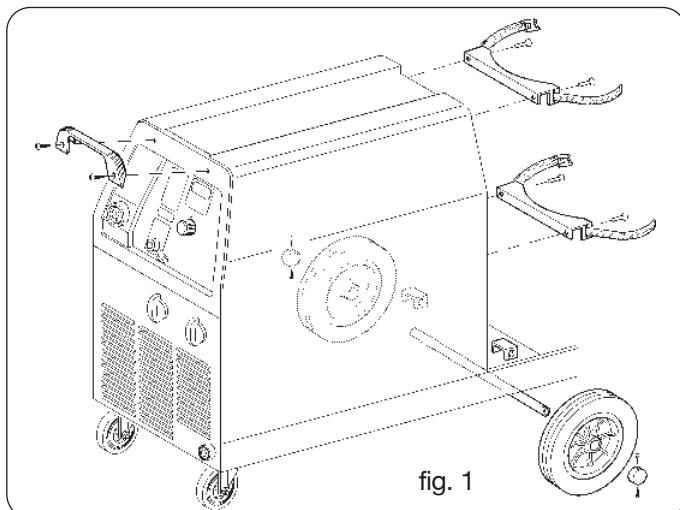

must be performed by qualified personnel.

3.2 INTERNAL CONNECTIONS

- Any intervention carried out inside the welding machine must be performed by qualified personnel.
- Before working inside the welding machine, make sure that the plug is disconnected from the power mains.
- After final inspection, the welding machine is connected to the voltage indicated on the power supply cable.
- To change the supply voltage, remove the right side panel and arrange the voltage change terminal board connections as shown in the figure.
- The supply voltage may not be changed on single-phase power sources.
- Do not use the welding machine without its cover or side panels for obvious safety reasons, and to avoid alter-

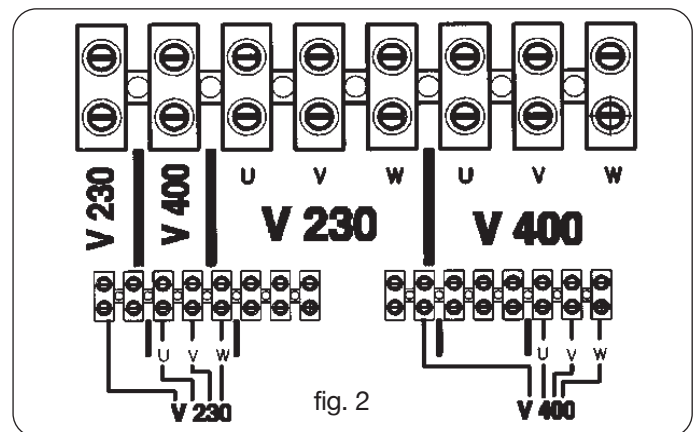

ing the cooling conditions for internal components.

- Connect a plug suitable for the absorbed current to the power supply cable.
- Connect the yellow-green wire of the machine mains to an efficient grounding socket.

3.3 EXTERNAL CONNECTIONS

3.3.1 Connecting the mass clip.

- - Connect the earth cable terminal to the socket of the welding machine, and connect the earth clamp to the workpiece.

3.3.2 Cylinder placement and connecting the gas hose

- Position the cylinder on the cylinder holder of the welding machine, using the straps provided to fasten it to the rear panel of the machine.
- **The gas cylinder must not be higher than 1.65m (Art. 576-577-579-581-583) and 1m (Art. 572-573), to avoid creating hazardous conditions.**
- Periodically check for wear on the straps, and order replacements if necessary.
- The cylinder must be equipped with a pressure regulator complete with flow gauge.
- Only after positioning the cylinder, connect the outgoing gas hose from the rear panel of the machine to the pressure regulator.
- Adjust the gas flow to approximately 10/12 liters/minute.

4 DESCRIPTION OF CONTROLS

4.1 CONTROLS ON THE FRONT OF THE MACHINE

A- Selection key.



Pressing this key causes the LEDs **B**, **C**, **D** and **E** to light in sequence.

From within the sub-menu activated by the 2 keys **Q** and **R**, select the Soft Start, PULL 2003 motor speed variation, and post gas functions.

B- Green LED (PROGRAM).



Signals that the display **S** shows the program number being used.

Check the instructions posted inside the mobile side panel for the diameter, wire type and gas corresponding to the program number displayed. The figure on the display **S** is always preceded by the letter **P**.

C- Green LED.

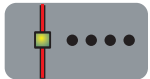

Signals that the display **S** shows the spot welding or working time. The length of this time is adjustable from 0.3 to 5 seconds. Setting the time to 0 disables the function. The function is active only while welding.

The value shown on the display **S** is always preceded by the letter **t**.

D- Green LED.

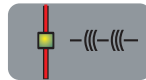

Signals that the display **S** shows the pause time between welding segments. The length of this time is adjustable from 0.3 to 5 seconds. Setting the time to 0 disables the function. The function is active only if the welding time is not 0 and while welding. The value shown on the display **S** is always preceded by the letter **t**.

E- Green LED (Burn-Back).

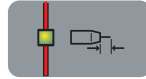

Signals that the display **S** shows the time for which the wire exits the welding torch, after the operator has released the torch trigger. This time ranges from 10 to 400 milliseconds. The value shown on the display **S** is always preceded by the letter **t**.

F- Yellow LED.



Lights when the thermostat interrupts the welding machine operation.

G- Green LED (PULSAR).

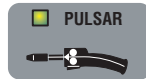

Lights and shuts off intermittently when the connector of the PULL 2003 torch or SPOOL-GUN is connected to the connector **I**.

H- Central adapter.

This is where the welding torch is to be connected.

I- 10-pin connector.

This connector must be connected to the 10-pin patch connector of the PULL 2003 torch or SPOOL-GUN. **L-M**

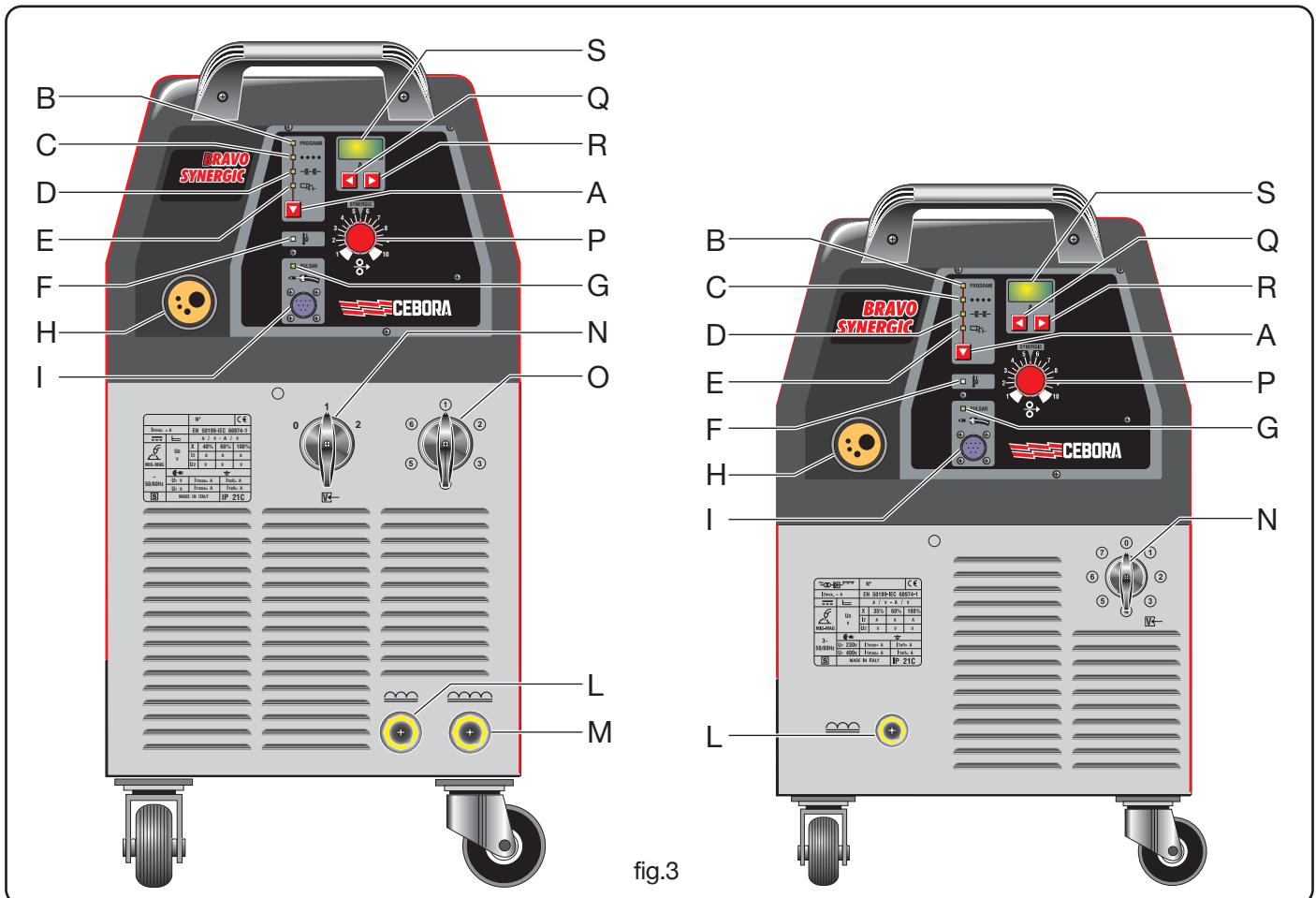

fig.3

Earth sockets.

Sockets to which to connect the earth cable. (Some versions have a single earth socket).

N- Selector switch.

Turns the machine on or off and selects the welding voltage ranges.

O- Selector switch.

Fine-tunes the welding voltage within the range selected with the selector switch **N**.

P- Setting knob.

Adjusts the wire speed, and is active only when using the standard welding torch and not the PULL 2003 torch or SPOOL- GUN.

When using the program 00, adjusts the welding wire speed from 0 to 20 meters/minute.

When using any synergic program, the knob indicator must be set to the label SYNERGIC. Choose a synergic program; the display **S** indicates the current set by the selected program. This current corresponds to a given speed. If you wish to correct this speed, simply turn the knob clockwise to increase or counter-clockwise to decrease. Changes in wire speed are always indicated on the display **S** by a current.

Q and R- Keys.



- When the LED **B** is lit, the display **S** shows the program number selected by the 2 keys. Once the selection has been completed the LED remains lit for 5 more seconds, then shuts off.

- When the LED **C** is lit the display **S** shows the time selected by the 2 keys. Once the selection has been completed the LED remains lit for 5 more seconds, then shuts off.

- When the LED **D** is lit, the display **S** shows the time selected by the 2 keys. Once the selection has been completed the LED remains lit for 5 more seconds, then shuts off.

- When the LED **E** is lit the display **S** shows the time selected by the 2 keys. Once the selection has been completed the LED remains lit for 5 more seconds, then shuts off.

- When the LEDs **B**, **C**, **D**, and **E** are off and we are within any synergic program, pressing one of the 2 keys will cause the display **S** to show either the current set or the recommended thickness in millimeters.

Adjusting the 2 selector switches **N** and **O** allows you to immediately see, on the display **S**, the increase or decrease in the value selected. This function is used when one wishes to know in advance at what current or thickness welding is to begin.

- **Pressing the 2 keys simultaneously for at least 5 seconds causes us to enter the sub-menu**, where we find 3 functions that may be selected via the key **A**:

1- Soft Start (speed).

Changes the wire speed from the one set; this speed remains active for the time governed by the Soft Start function (time).

The speed may be adjusted using the 2 keys **Q** and **R** from 10% to a maximum of 150% of the set welding speed.

This function, combined with the Soft Start function (time), serves to improve arc striking.

The value shown on the display **S** is preceded by the letter (A).

2- Speed set on the motor of the PULL 2003.

Adjusting the two keys **Q** and **R** varies the speed of the PULL 2003 from -9 to +9 compared to the set value. This function maximizes wire advancement, putting the wire feeder motor of the welding machine in step with the motor of the PULL 2003.

The value shown on the display **S** is preceded by the letter (H).

3- Post gas.

Using the two keys **Q** and **R**, it is possible to adjust the gas flow after welding to between 0 and 5 seconds. This function is especially useful when welding stainless steel and aluminum. The value shown on the display **S** is preceded by the letter (P).

4- Soft Start (time).

Adjusts the time for which the Soft Start speed remains active. This function, combined with the Soft Start function (speed), serves to improve arc striking.

Using the 2 keys **Q** and **R**, the Soft Start time may be adjusted from 0 to 1 second.

The value shown on the display **S** is preceded by the letter (d).

5- Two-stage manual mode and 4-stage automatic mode.

Adjust the 2 keys **Q** and **R** to select the **2-stage** or **4-stage** mode.

If the welding machine is set to **2-stage** manual mode, welding begins when the button **E** is pressed, and stops when it is released.

If the welding machine is set to **4-stage** automatic mode, press the torch trigger to begin welding; you may release the trigger once the procedure has begun.

Press and release the trigger again to stop welding. This setting is suitable for long-term welding, where the welder may tire of holding down the torch trigger. The value shown on the display **S** is preceded by the symbols (2T and 4T).

S- Display.

Using the manual program 00 the instrument displays the wire speed in meters per minute before welding, and the current while welding.

Using the synergic programs it always displays the current.

As described in the paragraphs above, the following may be displayed on the instrument before beginning to weld: the program being used, the spot welding time, the pause time, the Burn-Back time, the recommended thickness, the Soft Start function, the speed set on the motor of the PULL 2003, and the post-gas time.

5 WELDING

5.1 Installation

Make sure that the wire diameter corresponds to the diam-

eter indicated on the wire feeder roller, and that the selected program is compatible with the material and type of gas. Use wire feeder rollers with a "U"-shaped groove for aluminum wires, and with a "V"-shaped groove for other wires.

5.2 THE MACHINE IS READY TO WELD

When using the Pull-2000 or Spool-Gun torch, follow the instructions enclosed.

- Connect the earth clamp to the workpiece.
- Set the switch N to 1.
- Remove the gas nozzle.
- Unscrew the contact tip.
- Insert the wire in the wire liner of the torch, making sure that it is inside the roller groove and that the roller is in the correct position.
- Press the torch trigger to move the wire forward until it comes out of the torch.
- **Caution: keep your face away from the gun tube assembly while the wire is coming out.**
- Screw the contact tip back on, making sure that the hole diameter is the same as that of the wire used.
- Assemble the gas nozzle.

5.3 WELDING CARBON STEELS WITHOUT GAS PROTECTION. (only for Arts. 572 and 573).

Make sure that the cables are properly inserted on the terminal board, so that the poles match correctly (only for Art. 572 and 573, see figure 4).

To attain well connected and protected welds, always work from left to right and top to bottom. Remove all waste at the end of each welding session.

The flux-cored wire to be used is our Art. 1587, Ø 0.9mm.

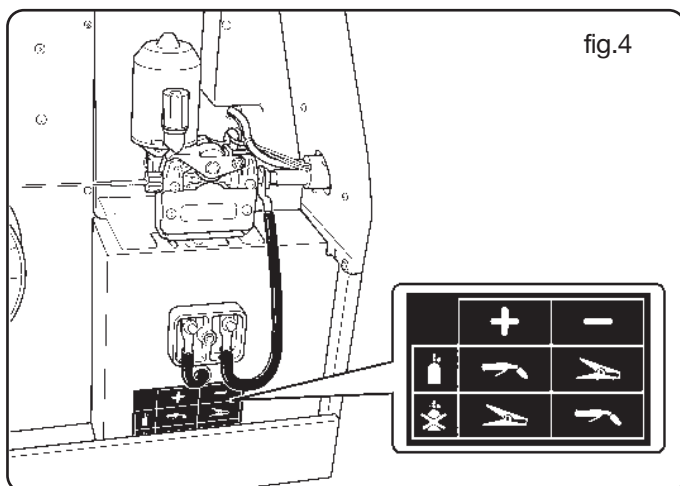

5.4 WELDING CARBON STEELS WITH GAS PROTECTION.

Make sure that the cables are properly inserted on the terminal board, so that the poles match correctly (only for Art. 572 and 573, see figure 5).

In order to weld these materials you must:

- Use a welding gas with a binary composition, usually ARGON + CO₂ with percentages of Argon ranging from 75% up. With this blend, the welding bead will be well jointed and attractive.
- Using pure CO₂ as a protection gas will produce narrow

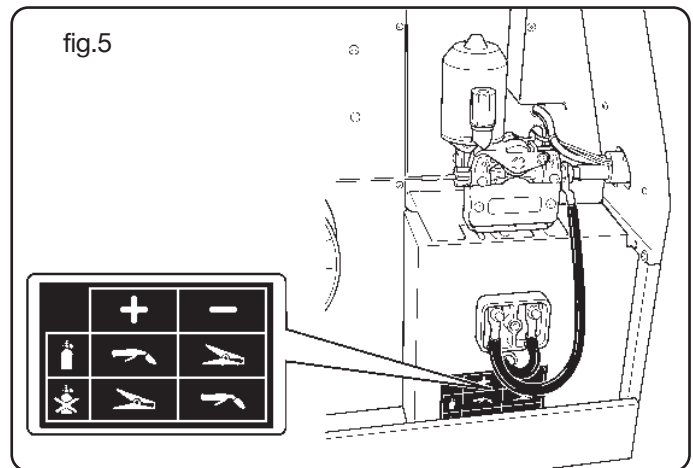

beads, with greater penetration but a considerably increase in splatters.

- Use a welding wire of the same quality as the steel to be welded. It is best to always use good quality wires, avoiding welding with rusted wires that could cause welding defects.
- Avoid welding rusted parts, or those with oil or grease stains.

5.5 WELDING STAINLESS STEEL

Make sure that the cables are properly inserted on the terminal board, so that the poles match correctly (only for Art. 572 and 573, see figure 5).

Series 300 stainless steels must be welded using a protection gas with a high Argon content, containing a small percentage of O₂ or carbon dioxide CO₂ (approximately 2%) to stabilize the arc.

Do not touch the wire with your hands. It is important to keep the welding area clean at all times, to avoid contaminating the joint to be welded.

5.6 WELDING ALUMINUM

Make sure that the cables are properly inserted on the terminal board, so that the poles match correctly (only for Art. 572 and 573, see figure 5).

In order to weld aluminum you must use:

- Pure Argon as the protection gas.
- A welding wire with a composition suitable for the base material to be welded.
- Use mills and brushing machines specifically designed for aluminum, and never use them for other materials.
- In order to weld aluminum you must use the torches: PULL 2003 Art. 2003 or SPOOL-GUN Art. 1562 with the connection Art. 1196.

6 WELDING DEFECTS

- 1 DEFECT- CAUSES
- Porosity (within or outside the bead)
 - Electrode defective (rusted surface)
 - Missing shielding gas due to:
 - low gas flow
 - flow gauge defective
 - regulator frosted due to no preheating of the CO₂ protection gas
 - defective solenoid valve
 - contact tip clogged with spatter

- gas outlet holes clogged
 - air drafts in welding area.
- 2 DEFECT CAUSES
- Shrinkage cracks
 - Wire or workpiece dirty or rusted.
 - Bead too small.
 - Bead too concave.
 - Bead too deeply penetrated.
- 3 DEFECT CAUSES
- Side cuts
 - Welding pass done too quickly
 - Low current and high arc voltages.
- 4 DEFECT CAUSES
- Excessive spraying
 - Voltage too high.
 - Insufficient inductance.
 - No preheating of the CO₂ protection gas

7 MAINTAINING THE SYSTEM

- Shielding gas nozzle

This nozzle must be periodically cleaned to remove weld spatter. Replace if distorted or squashed.

- Contact tip.

Only a good contact between this contact tip and the wire can ensure a stable arc and optimum current output; you must therefore observe the following precautions:

A) The contact tip hole must be kept free of grime and oxidation (rust).

B) Weld spatter sticks more easily after long welding sessions, blocking the wire flow.

The tip must therefore be cleaned more often, and replaced if necessary.

C) The contact tip must always be firmly screwed onto the torch body. The thermal cycles to which the torch is subjected can cause it to loosen, thus heating the torch body and tip and causing the wire to advance unevenly.

- Wire liner.

This is an important part that must be checked often, because the wire may deposit copper dust or tiny shavings. Clean it periodically along with the gas lines, using dry compressed air.

The liners are subjected to constant wear and tear, and therefore must be replaced after a certain amount of time.

- Gearmotor group.

Periodically clean the set of feeder rollers, to remove any rust or metal residue left by the coils. You must periodically check the entire wire feeder group: hasp, wire guide rollers, liner and contact tip.

8 ACCESSORIES

Art. 2003 Pull 2003 torch with UP/DOWN command on grip.

Art. 1562 Spool-gun torch with potentiometer on grip.

Art. 1196.00 6-meter connection for 1562.

Art. 1196.20 12-meter connection for 1562.