

CITOMIG XP

A full range of MIG-MAG equipment featuring switch-based intuitive adjustment.



2006-287

2003-391

CITOMIG XP, a long history between the OERLIKON b

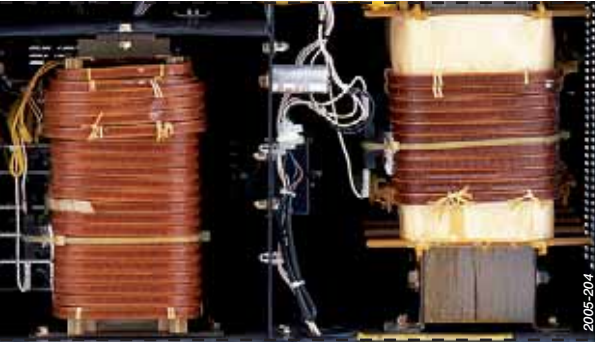

All our XP range OERLIKON generators have been designed with robust, well-calibrated components meeting the most demanding requirements.

OERLIKON solution

The ideal industrial solution employing top technology in each component of the set.

Optimised power source

Simple and reliable circuitry to guarantee optimal welding, quality with minimum maintenance, ideal for large production runs.

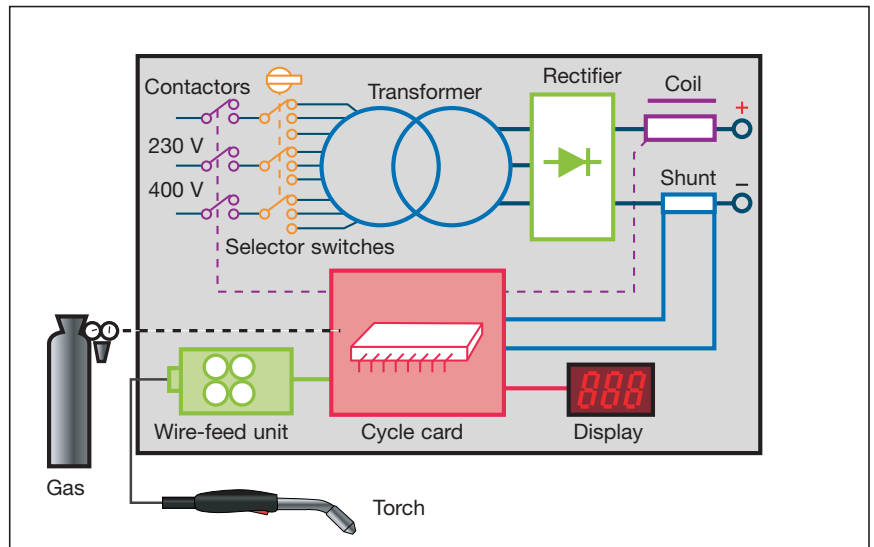

Technological development

OERLIKON has equipped CITOMIG sets with digital wire speed regulation, maintaining a constant value in the wire-feed supply, and especially in the torch, regardless of variations in resistance. Combining excellent wire feed regularity with optimised calibration of the electromagnetic parts, CITOMIG sets produce a perfectly stable arc for top-quality weld beads in terms of defects and surface appearance.

Intuitive adjustment

After entering the consumable parameters (wire grade / diameter and gas), the operator selects the thickness to be welded and the system immediately provides optimised adjustment values for the welding operation.





2006-289

With its CITOMIG range OERLIKON offers welding sets employing highly developed and carefully applied technology. This robust and reliable range will always meet the challenge, even under heavy duty conditions.

CITOMIG

CITOMIG sets available in air or water, compact or separate versions, meet every need and offer the following advantages:

Product features:

- Three-phase, dual-voltage power supply allowing connection to any type of three-phase power supply.
- Digital parameter display (plate thickness / current / wire speed).
- 4-rollers feed with speed regulation system providing constant wire feed.
- "Assisted adjustment" mode taking into account the thickness to be welded.
- "Spatter reduction" system based on coil saturation after the striking phase.
- 2T/4T/spot/intermittent welding modes for an optimised operating procedure.
- Ventilation automatically operates when required.
- 2 coil positions.
- Plug-in harnesses on generator side.
- Fully sheathed and shielded harness for greater robustness.
- Ultra-compact wire-feed unit designed for restricted access.
- Wire-feed unit delivered with the possibility of wire speed adjustment and equipped with gas purge.



2006-368



2006-787

Top performance under all conditions



2000-024

Every company producing industrial goods aims to combine high productivity with quality. CITOMIG sets, with their special construction, measures adapted to all the components of the set, are a perfect response to this requirement. This requirement arises in sectors such as infrastructure, railway and road construction and boiler making.

Infrastructure

Infrastructure represent an important sector. OERLIKON covers a wide range of infrastructure applications and proposes global solutions including manual and automatic equipments, consumables and services.

Through its worldwide network OERLIKON provides the after sales service and welding expertise required to produce highly technical structures.

Boiler making

Perfectly targeted for all steel boiler making activities, CITOMIG sets provide the quality and productivity required for highly competitive welding.

The various accessories and options available for this range offer the ideal response to all requirements in this sector.



2000-462



2000-167

MIG-MAG process performance levels

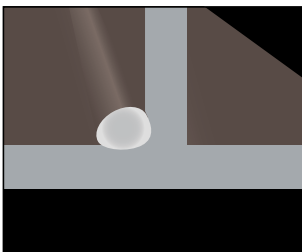

Short-Arc MIG, thickness < 3.0 mm.

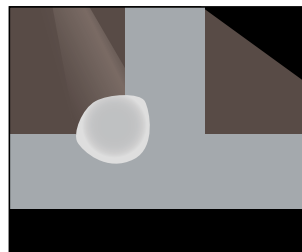

Spray-Arc MIG, thickness < 10 mm.

This type of machine has been carefully developed to offer excellent welding quality with no deterioration over time, and provides unrivalled durability under the toughest conditions. Another essential advantage at the process level is that the instantaneous current is never limited so that the power source delivers exactly the current required by the process. This is a considerable advantage when welding aluminium of medium and high thickness.

Rail transport

Railway applications also require exemplary welding quality to withstand high mechanical strain accentuated by permanent vibration. This concerns both manufacture and workshop or on-site repairs.

CITOMIG sets, providing high arc stiffness and constant welding parameters, meet this requirement perfectly.



Road transport

This sector has a lower potential for automation and therefore requires the use of welding sets with an optimal quality/price ratio.

High quality welding, long service life, low maintenance: CITOMIG sets provide a very favourable response to these criteria which optimise the cost of the welding operation.



MIG-MAG process performance levels



Joint filling with cored wire
Spray-Arc MIG, thickness < 25 mm.



Penetration pass
Short-Arc MIG, thickness < 25 mm.

Simplicity of assisted adjustment according to plate th



2006-390

All the essential elements for these applications are included in the CITOMIG range.

- Compact and separate wheel-mounted sets and cylinder holders
- Lightweight and robust wire-feed unit with trolley and pivot
- Assisted adjustment system
- Digital display of voltage, wire speed and current
- Complete cycle



2006-286

Items on the front panel

- 1 Display unit
- 2 Wire feed / gas purge
- 3 Wire feed unit socket
- 4 Earth socket
- 5 Display selector switch
- 6 Mode selector switch
- 7 Wire speed / time adjustment
- 8 Voltage switches
- 9 Coil positions

Items on the CITOMIG generator

- A Manoeuvring handle
- B Front control panel
- C Lifting eyes
- D Power source
- E Portable wire-feed unit on trolley or pivot arm
- F Torch
- G Compartment for cooling unit
- H Swivel rollers



2006-287

CITOMIG 400 XP, the first switch-based intuitive-adjustment MIG-MAG set available on the market, is designed to allow easy and reliable access to the best adjustment based on the thickness of the weld piece. Easy use with assisted adjustment according to the thickness of the plate and selection of the ideal fusion mode for the type of material to be welded - Steel - Stainless steel - Aluminium.

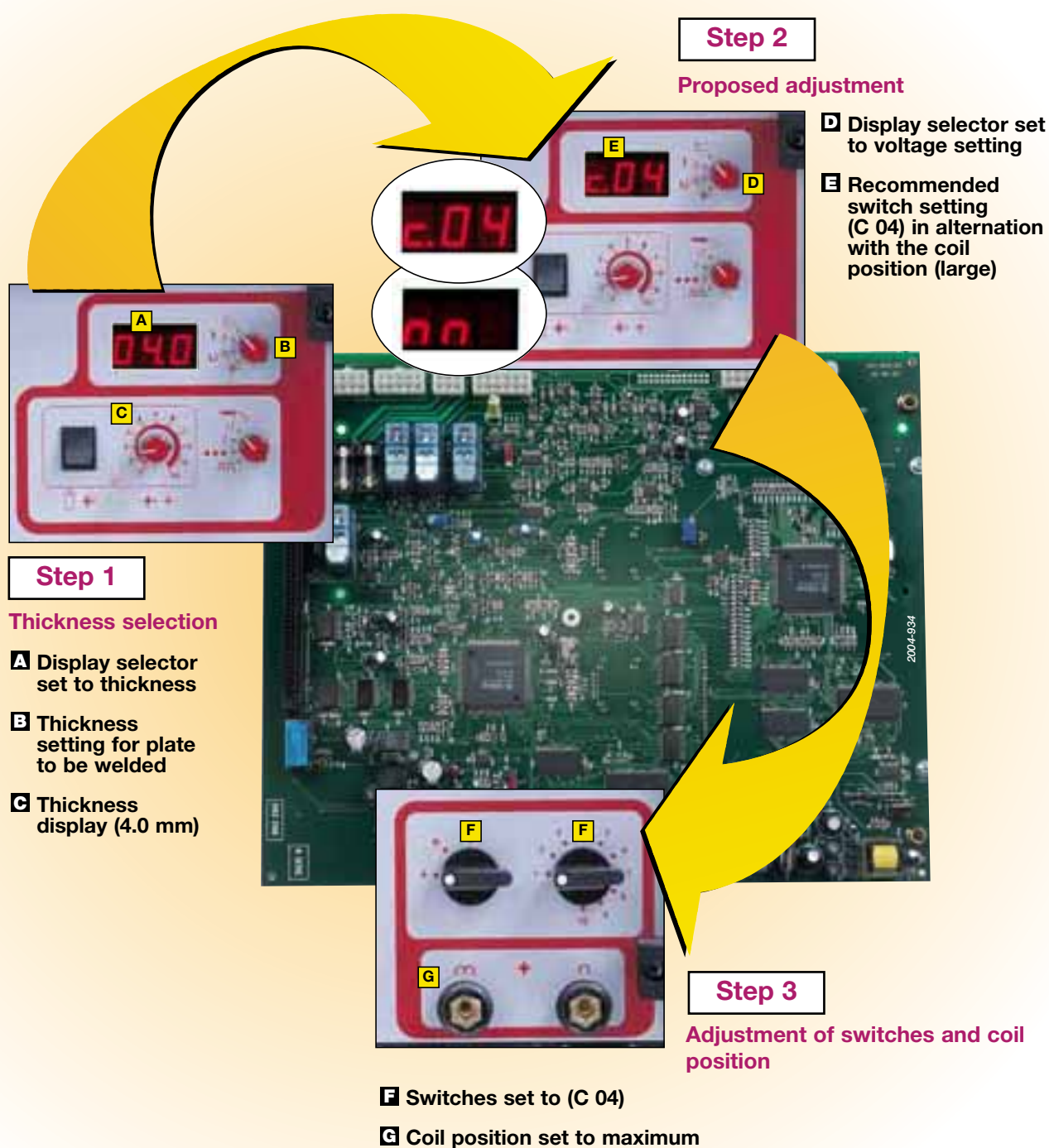



2000-434

Excellent striking and fusion quality. Initial welding mode: spot. Digital display unit. 2T / 4T control. Possibility of adjusting the cycle parameters - Pre-gas - Post-gas - Wire speed at striking and dynamism of striking. Regulated wire feed speed. Possibility of polarity inversion. Gas purge and wire feed. Cylinder holder. Large diameter wheels built into the bodywork.

A complete welding cycle

To guarantee welding quality the power source must be equipped with all the adjustments required for a complete weld cycle.

CITOMIG sets feature these elements, even beyond current requirements.

The diagram below shows all the possibilities offered by the OERLIKON range.

Metal transfer

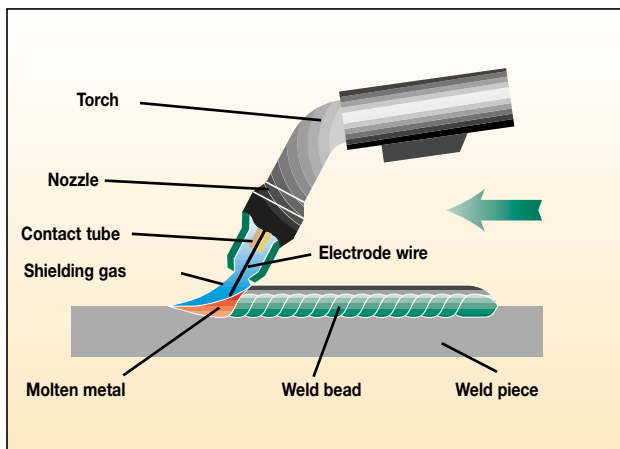

Schematic diagram

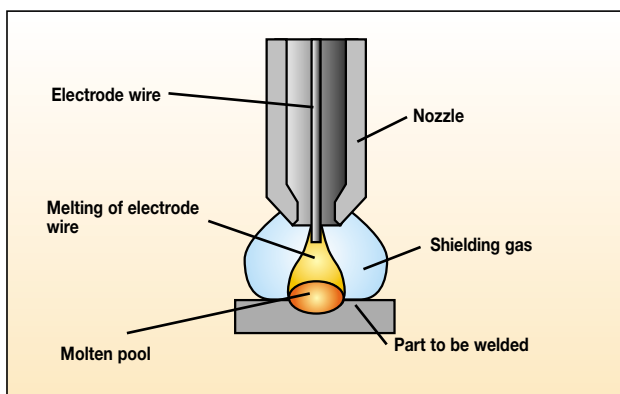

Welding cycle

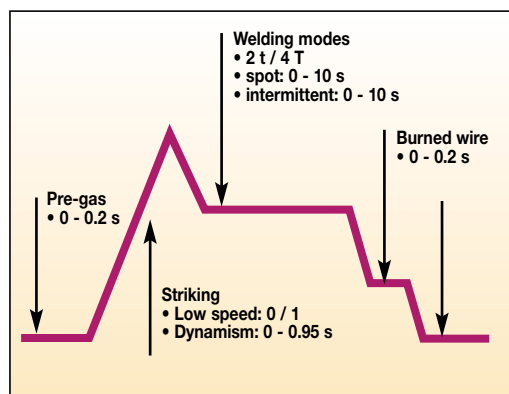

Impressive technical characteristics



Technical characteristics:		CITOMIG 300 XP	CITOMIG 400 XP	CITOMIG 500 XP
Primary power supply		220 V - 400 V three-phase		
Maximum current drain		27 A - 16 A	47 - 27 A	63.3 - 36.6 A
Open circuit voltage		16.5 - 35.8 V	16.6 - 45.8 V	15.8 - 50.4 V
Duty cycle	35 %	270 A	380 A (40 %)	480 V (50 %)
	60 %	240 A	320 A	410 A
	100 %	300 A	300 A	370 A
Number of steps		12	30	30
Number of rollers		4		
Dimensions		825 x 390 x 821 mm	925 x 580 x 1 060 mm	925 x 580 x 1 060 mm
Weight		101 kg	161 kg	201 kg
Standards		EN 60974-1		
Basic set				
Compact air		W 000 260 959	W 000 260 961	-
Compact water		-	W 000 260 962	-
Separate air		W 000 260 960	W 000 260 964	W 000 260 965
Separate water		-	W 000 260 963	W 000 260 966
Ready-to-use set				
Compact air		W 000 261 771	W 000 261 774	-
Compact water		-	W 000 261 773	-
Separate air		W 000 261 772	W 000 261 775	-
Separate water		-	W 000 261 776	W 000 261 777
Options and additions				
Wire-feed units		DV 4004 XP		
Harness length	Air	5 m	W 000 260 999	
		10 m	W 000 261 000	
	Water	5 m	W 000 261 001	
		10 m	W 000 261 002	
Number of rollers		4		
Trolley		40 645 003		
Lifting eyes		40 645 391		
Pivoting wire-feed unit support		W 000 055 048		

Torch		CITORCH M 341	CITORCH M 341 W	CITORCH M 441	CITORCH M 441 W
Air	3 m	W 000 261 559	-	W 000 261 563	-
	4 m	W 000 261 561	-	W 000 261 564	-
	5 m	W 000 261 562	-	W 000 261 568	-
Water	3 m	-	W 000 261 573	-	W 000 261 576
	4 m	-	W 000 261 574	-	W 000 261 577
	5 m	-	W 000 261 575	-	W 000 261 578



Contacts in Europe

BELGIUM

AIR LIQUIDE WELDING BELGIUM SA
Z.I. West Grijsen - Grijsenlaan 5 - 3300 Tienen
Tel.: +32 16 80 48 20 - Fax: +32 16 78 29 22

CZECH REPUBLIC

AIR LIQUIDE CZ S.R.O.
Jinonická 80 - 15800 Praha 5
Tel.: +420 257 290 384 - Fax: +420 257 290 428

GERMANY

OERLIKON SCHWEISSTECHNIK GmbH
Industriestrasse 12 - D-67304 Eisenberg/Pfalz
Tel.: +49 6351 4760 - Fax: +49 6351 476 335

HUNGARY

AIR LIQUIDE HUNGARY
IPARI GAZTERMELŐ KFT.
Pannonia Center-Pannonia u.11. - H-1136 Budapest XIII,
Tel./Fax: +36 20 489 8617

NETHERLANDS

AIR LIQUIDE WELDING NETHERLANDS
Rudonk 6 B - NL 4824 AJ Breda
Tel.: +31 76 541 00 80 - Fax: +31 76 541 58 96

POLAND

AIR LIQUIDE WELDING POLSKA - SP. Z.o.o
UL. Porcelanowa 10 - 40-246 Katowice
Tel.: +48 32 609 04 50 - Fax: +48 32 609 04 60

PORTUGAL

AIR LIQUIDE SOLDADURA LDA
Rua Dr. António Loureiro Borges, 4-2º Arquiparque
Miraflores - 1495-131 Algés
Tel.: +351 21 41 64 900 - Fax: +351 21 41 69 40

ROMANIA

DUCTIL
Aleea Industriilor Nr 1 - 120224 Buzau
Tel.: +40 238 722 058 - Fax: +40 238 716 861

SCANDINAVIA

OERLIKON SKANDINAVIEN AB
Krossverksgatan 7 - 216 16 Limhamn
Tel. : +46 (0)40 670 15 00 - Fax : +46 (0)40 670 15 01

SLOVAKIA

FRO KOVOPLAST S.R.O.
Pražska 35 - 94901 Nitra
Tel.: +421 37 65 19 919 - Fax: +421 37 65 19 919

SPAIN

OERLIKON SOLDADURA SA
Poligono Industrial la Noria - Carretera de Castellon
Km-15,500 - 50730 El Burgo de Ebro - Zaragoza
Tel.: +34 976 10 47 00 - Fax: +34 976 10 42 67

SWITZERLAND

OERLIKON - SCHWEISSTECHNIK-AG
Neunbrunnenstrasse 50 - CH 8050 Zürich
Tel.: +41 44 307 61 11 - Fax: +41 44 307 65 30

U. K.

AIR LIQUIDE WELDING Ltd
Low March / London Road - Daventry - Northants NN11 4SD
Tel.: +44 1 327 70 55 11 - Fax: +44 1 327 70 13 10

For other countries contact our export services

ALW Italy Export Service

Via Torricelli15/A
37135 Verona - Italy
Tel: +39 045 82 91 511
Fax: +39 045 82 91 536

ALW France Export Service

13, rue d'Epluches - BP 70024 Saint Ouen l'Aumône
95315 Cergy-Pontoise Cedex - France
Tel: +33 1 34 21 33 33
Fax: +33 1 30 37 19 73

www.oerlikon-welding.com



Created in 1902, now world leader in industrial and medical gases and associated services, Air Liquide is present in 70 countries and has 35,900 employees. Using constantly renewed technologies, Air Liquide develops innovative solutions contributing to the manufacture of numerous products used in daily life and assists the preservation of life.